

Back to Basics

With

Auto-Solve

Topic 7

Electronic Fuel Injection (Part 2)

Injector Duration

The multi-point injector is an electro-mechanical device, which is fed by a 12 volt supply from either the fuel injection relay or from the Electronic Control Module (ECM). The injector consists of a solenoid operated valve, which is held in the closed position by a spring until the ECM completes the earth circuit. When the electromagnetic field lifts the pintle off its seat, fuel is delivered to the engine. The total lift on the pintle is approximately 0.15 mm (6 thou) and has a reaction time around 1 millisecond.

The voltage at the injector will only be present when the engine is cranking or running, due to the voltage supply being controlled by a tachometric relay.

The injector is supplied with fuel from a common fuel rail. The length of time that the injector is held open for will depend on the input signals seen by the engine management ECM from its various engine sensors. These input signals will include: -

- The resistance of the coolant temperature.
- The output voltage from the airflow meter (when fitted).
- The resistance of the air temperature sensor.
- The signal from the Manifold Absolute Pressure (MAP) sensor (when fitted).
- The position of the throttle switch / potentiometer.

The held open time or injector duration will vary to compensate for cold engine starting and warm-up periods, i.e. a large duration that decreases the injection time as the engine warms to operating temperature.

The duration time will also expand under acceleration and contract under light load conditions.

Depending on the system encountered the injectors can fire either once or twice per cycle. The injectors are wired in parallel with simultaneous injection and will all fire together at the same time (**Fig 1.0**).

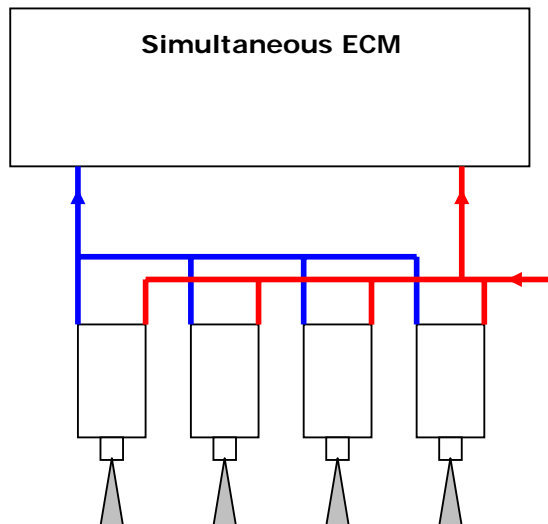

Fig 1.0

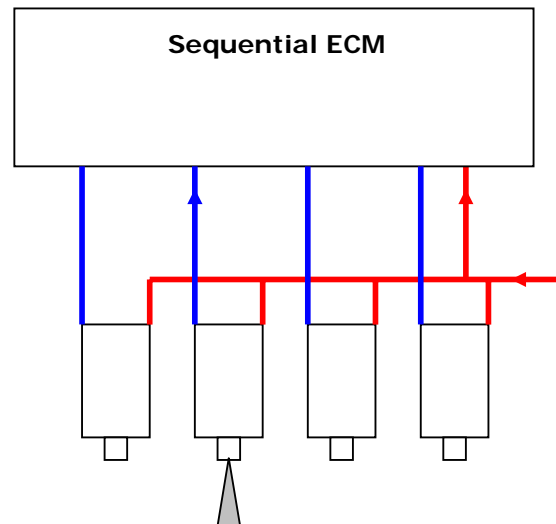

Fig 1.1

Sequential injection, as with simultaneous, has a common supply to each injector but unlike simultaneous, having a separate earth path for each injector (**Fig 1.1**). This individual firing allows the system, when used in conjunction with a phase sensor, to deliver the fuel when the inlet valve is open and the incoming air helps to atomise the fuel.

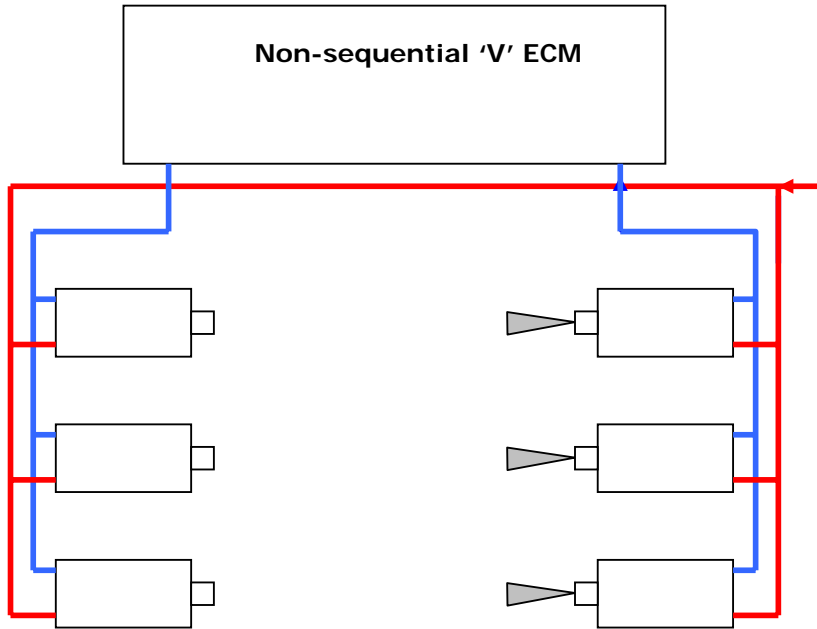

Fig 1.2

It is also common for injectors to be fired in 'banks' on 'V' configuration engines (**Fig1.2**). The fuel will be delivered to each bank alternately. In the case of a Jaguar V12 the injectors are fired in 4 groups of 3 injectors.

Because of the frequency of the firing of the injectors, it is expected that a sequential injector will have twice the duration, or opening time, than that of a simultaneous pulse. This will however be determined by the injectors flow rate and the fuels operating pressure.

In the waveform illustrated below (**Fig 1.3**) we can observe the current drawn by the injector (shown in red) at the same time as monitoring the primary ignition trace (shown in blue). The main reason for evaluating these two waveforms together is to identify the cause of a non-start situation or sudden loss of power, causing the engine to stop. If the primary trace is absent, there will be no switching of the injectors as these two circuits are timed together while the loss of the injector current signifies that a fault has occurred within the injection circuit.

The frequency of the injection trace when compared to the primary signal will differ between sequential and simultaneous injection. Sequential having one pulse per 720°, while simultaneous will predominantly have two. Some simultaneous systems do however have a single pulse, but these are in the minority.

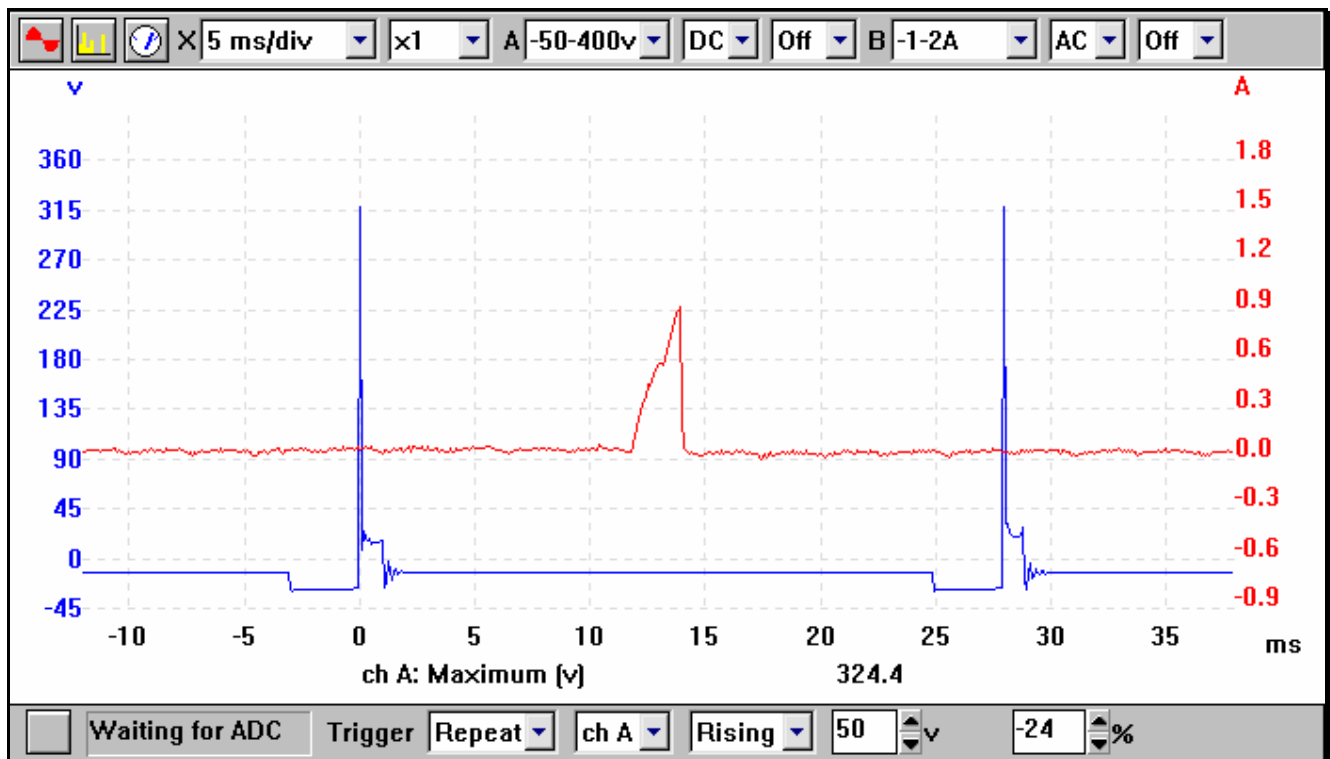

Fig 1.3

Engine Sensors

The following sections detail the inputs into the vehicles ECM that contribute towards the desired injector duration. While certain components may not be fitted on some systems, the text endeavours to cover all variants.

Coolant Temperature Sensor

The coolant temperature sensor is a small two connection device that has the function of reporting the engine's temperature back to the ECM. It is this signal which will determine the engine's warm-up enrichment and the engine's fast idle speed.

This sensor will normally have a Negative Temperature Coefficient (NTC), which means that the component's resistance will reduce as the temperature increases. A Positive Temperature Coefficient (PTC) sensor is not as common as the NTC and its resistance will react to temperature in the opposite way.



Fig 1.4

To increase the vehicles driveability and performance on pre 1992 non-cat cars, the resistance can be altered by calculating and inserting a resistor in series with the coolant temperature sensor, however, this resistance has to be calculated before its insertion. The resistor should not be inserted in series when the CTS is an NTC device. It should also be noted that the resistor should *not* be placed in parallel, as this will reduce the overall resistance. This modification *cannot* however be implemented on engines equipped with a catalytic converter as this extra fuelling will upset the corrective nature of the lambda or oxygen sensor.

The sensors are manufacturer specific and the outputs will vary dramatically although they may look identical. Any poor connections on this circuit will introduce an extra resistance in series and will falsify the readings that the ECM sees - reading the resistance at the ECM multi-plug will confirm this.

Fig 1.4 illustrates Ford's version of a coolant temperature sensor.

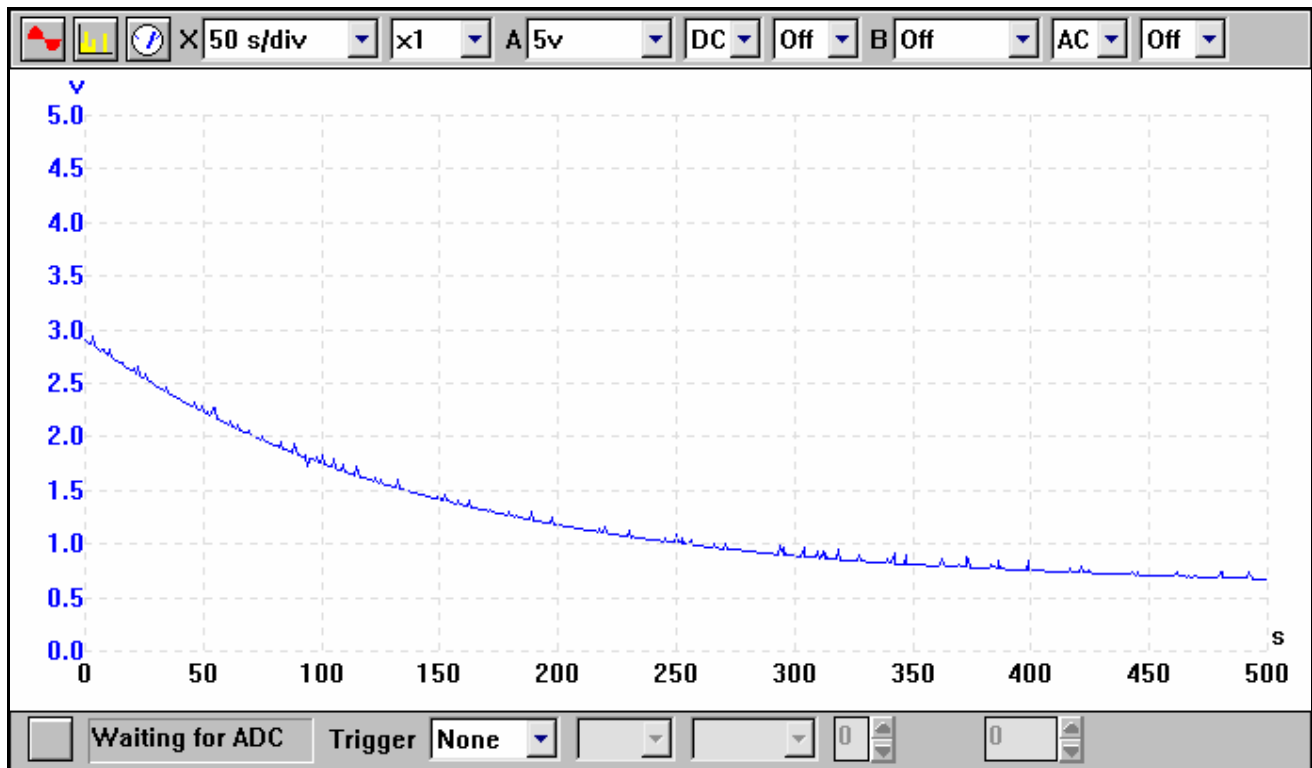

Fig 1.5

The Coolant Temperature Sensor (CTS) will invariably be a two wire device with a voltage supply at approximately 5 volts.

The sensor itself has the ability to alter its resistance with engine temperature change. The majority of sensors have a Negative Temperature Coefficient (NTC), which results in the resistance of the component decreasing as the temperature increases. The resistance change will therefore alter the voltage seen at the sensor and can be monitored for any discrepancies across its operational range.

By selecting a time scale of 500 seconds, connect the oscilloscope to the sensor and observe the output voltage.

Start the engine and in the majority of cases the voltage will start in the region of 3 to 4 volts, however this voltage will depend on the temperature of the engine, as the temperature increases the resistance decreases and the voltage will also be seen to drop. See **Fig 1.5**.

The rate of voltage change is usually linear with no sudden changes to the voltage, if the CTS displays a fault at certain temperature, this is the only true way of detecting it.

Vauxhall CTS

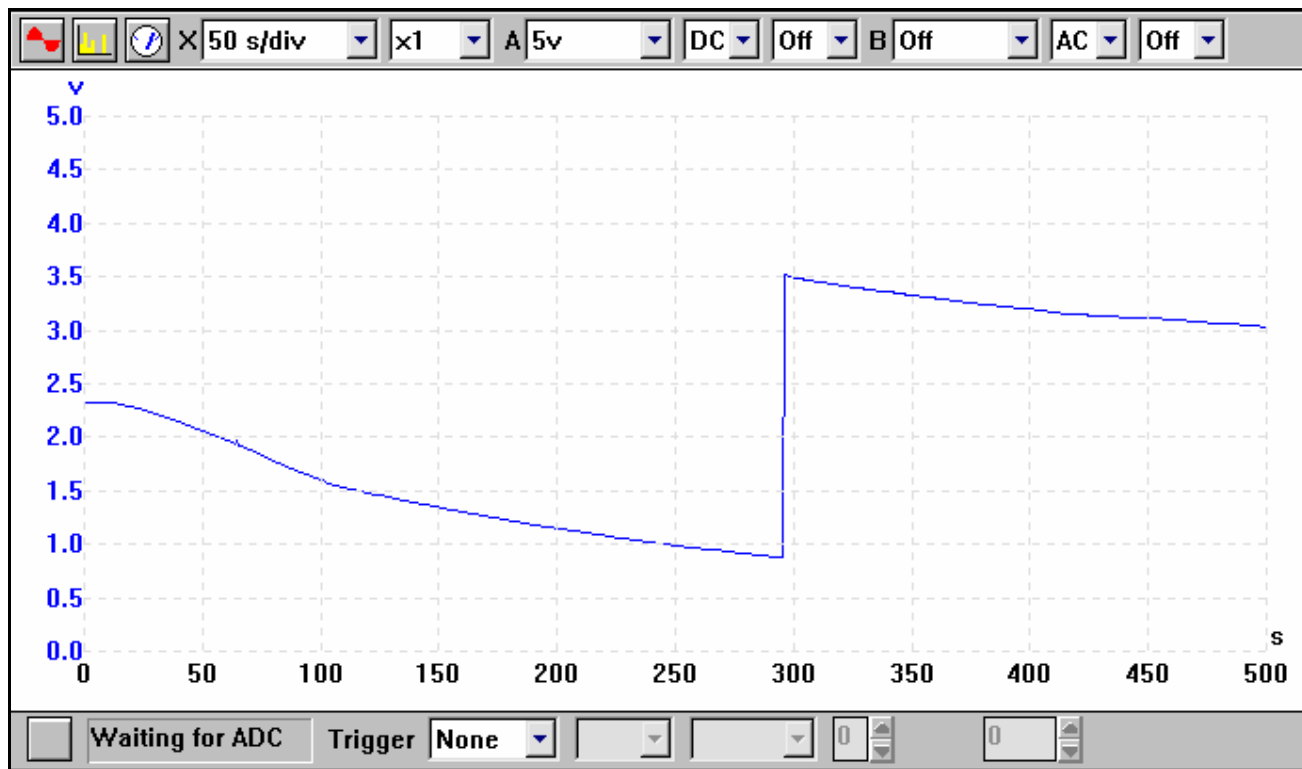

Fig 1.6

The CTS used in the Multec system on the Vauxhall Vectra 1.6 Lt. engine has a distinctive waveform when viewed on the oscilloscope. The voltage seen at the CTS will display a conventional voltage reduction until the engine reaches 40° - 50 °C, at which point the voltage rises dramatically due to internal switching inside the Electronic Control Module (ECM). This is illustrated in **Fig 1.6**. The reason for the voltage change is that at higher operating temperatures (50° C plus), the ECM is now able to offer finer control with the increased voltage.

All the example waveforms used were recorded using a PC based oscilloscope loaned by www.picotech.com. Other manufacturers equipment will have different voltage ranges but the resultant picture should be very similar.

Next month we will continue looking at the other sensors who's inputs effect the injector duration.